

STRUT ASSIST

QUALIFIER

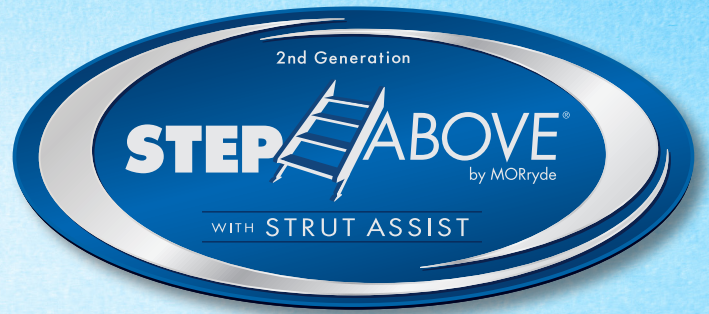

BEFORE YOU BEGIN

Please note these compatibility limitations:



The **StepAbove** with Strut Assist is NOT compatible with units that have an interior step well or where the interior wall is thicker than the door frame.



Units known to be incompatible:
- **DRV** (wall depth & door width)
- **Riverstone** (wall depth)



If your unit has a door strut that prevents the door from fully opening, the strut must be removed and cannot be used with the strut step.



Above. Beyond. Always.

574.293.1581 • www.MORryde.com

MEASURING

STEP 1 THE UNIT MUST BE LEVEL TO ENSURE ACCURATE MEASUREMENTS.

NOTE: Steps 2 and 3 are required to ensure that the threshold is compatible with the hinge plate.

STEP 2

THRESHOLD

NOTE: It is recommended that you remove the transition strip before measuring the threshold.

The rise of the threshold must be between 5/8" and 3/4". If it is greater or less than either of these measurements, the door may not close properly.

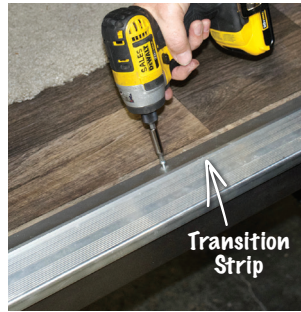

STEP 3

HINGE PLATE

To allow room for the hinge plate, there must be a 3/8" gap from the bottom of the entry and screen doors to the top of the threshold. Without this clearance, the door will not have sufficient room to close when the steps are down.

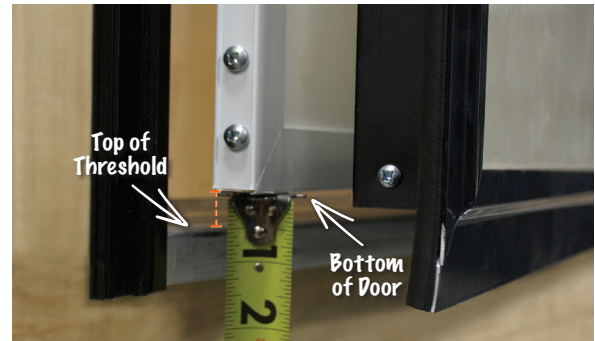

STEP 4

SKIRT CLEARANCE

Located below the threshold, this area can obstruct the operation of the step if it extends too far and is too close to the bottom of the threshold (see graphic below).

Minimum Dimension: 1.25" beyond threshold

Maximum Dimension: 1.0" below threshold

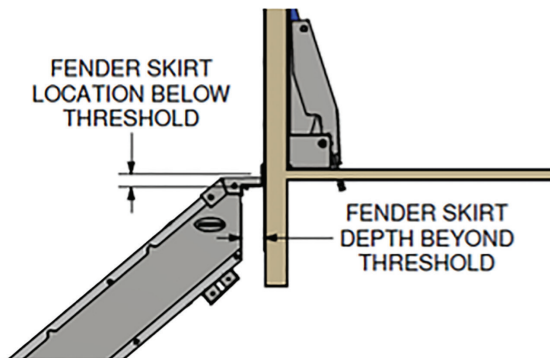

STEP 5

DOOR WIDTH

On the side or edge of the door, find the door width on the factory label.

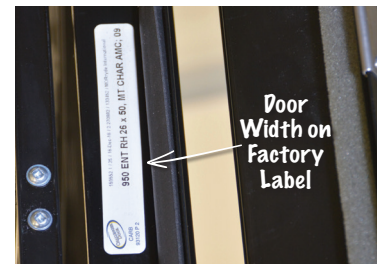

If there is no label, then on the inside of the door frame, measure from flange to flange at the base of the door. Refer to the Fit Chart on the last page for the door width. Keep in mind that the flange-to-flange measurement needed is the narrowest part of the entry door.



STEP 6

STEP HEIGHT

Find the step height by measuring from the top of the threshold to the ground. Referring to the STEP HEIGHT column, use the Fit Chart on the last page to determine which step products will fit the unit.

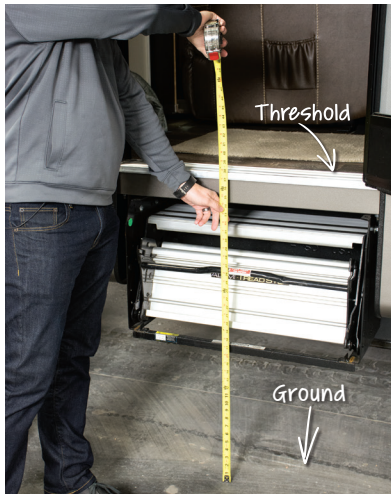

STEP 7

CLEARANCE FOR STRUT STEP

(As determined by looking out of the doorway from inside the unit - see graphic below)

- A** There must be a minimum of 4.0" on either side of the door to allow for clearance of the strut hinge.
- B** There must be a minimum of 14.25" of vertical space on the right side to allow clearance of the strut cover.
- C** On the left side, there must be a minimum of 5.0" of vertical clearance from the floor of the unit to allow the hinge to rotate.
- D** There must be a minimum depth clearance of 6.0" to allow the strut hinge to mount and rotate.

NOTE: Usually the fire extinguisher will be in this location and therefore must be relocated.

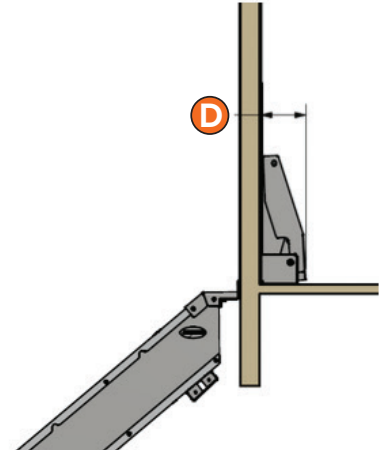
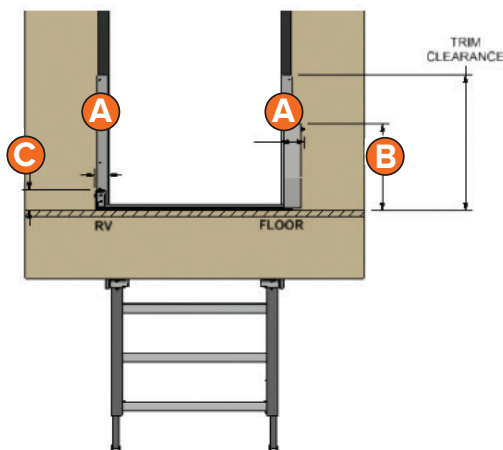
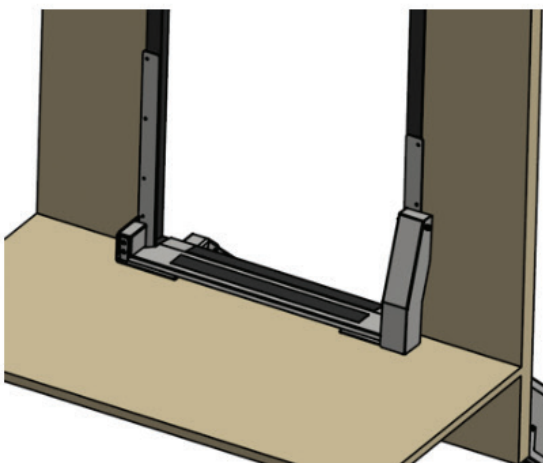

STEP 8

WALL THICKNESS AND DOOR TRIM

Measure the depth of the wall relative to the interior side of the door flange. If the wall is not flush to the backside of the door flange, shims will be required to mount the strut step properly. (Shims are included in the kit).

- The shim kit has 3 different-sized shims that can be combined to fill a gap of up to 7/16". If the gap is larger than 7/16", additional shims will be needed (not included).
- NOTE:** To allow for the strut hinge to sit flush against the backside of the door frame, the door trim will need to be notched measuring 22-1/8" up from the floor.

If you have questions or need assistance, please call our Parts Department at 574.293.1581.

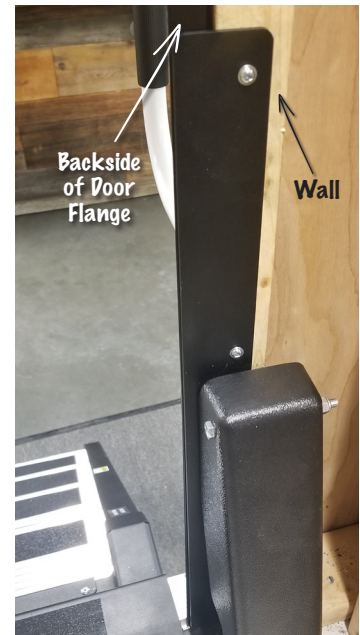

STRUT ASSIST FIT CHART

	PART NUMBER *	STEP HEIGHT	STEP RISE	DOOR WIDTH Size from Factory Label	—OR—	DOOR WIDTH Size from Flange to Flange
3 STEP	STP-205	30.5" – 36.5"	9"	26"		23.75" – 24.25"
	STP-210	30.5" – 36.5"	9"	30"		27.75" – 28.25"
4 STEP	STP-211	37" – 43.5"	8"	26"		23.75" – 24.25"
	STP-214	37" – 43.5"	8"	30"		27.75" – 28.25"



Motion Activated Lights



STP54-032

Storage Box



SP54-099

Step Handrails



3 STEP - STP214-121H
4 STEP - STP214-120H

Be sure to check out our **StepAbove® Accessories.**



Above. Beyond. Always.

574.293.1581 • www.MORryde.com